

aquatica®

*Function, Form & Fashion*



## *Galaxy MCSQ-540 Built-in Shower Head*

---

IT | Istruzioni di montaggio e manutenzione  
UK | Installation and maintenance instructions  
F | Instructions d'installation et entretien

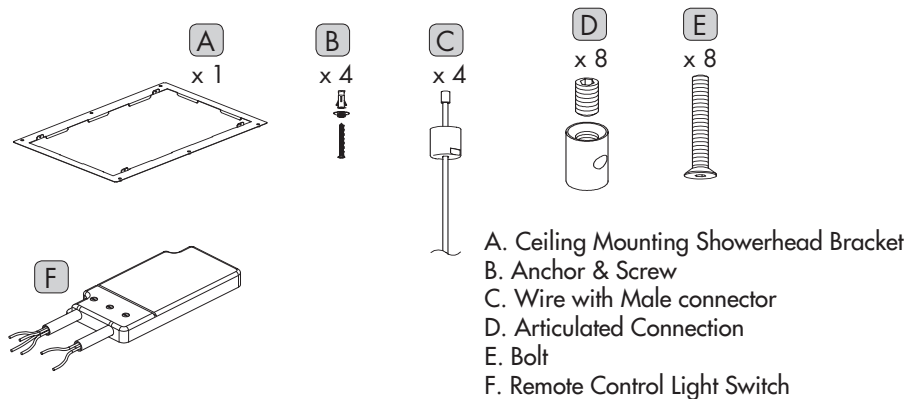

Utensili necessari / Tools needed / Outils nécessaires

Indossare guanti di protezione  
Wear protective gloves  
Utiliser des gants isolants de protection

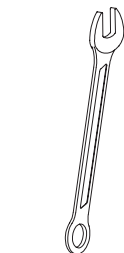
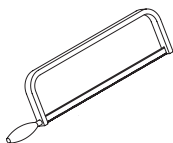
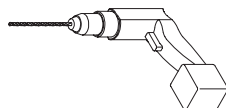
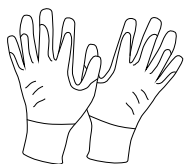

CH 18



3 mm (1/8")

2mm (1/8")



**ATTENZIONE!!!!**

Tutte le operazioni di installazione e manutenzione richiedono l'ausilio di NR. 2 OPERATORI SPECIALIZZATI

**WARNING!!!!**

All installation and maintenance operations require 2 QUALIFIED WORKER

ATTENTION : Toutes les opérations de pose et d'entretien nécessitent de Nr.2 opérateurs



Pulsantiera accensione luci  
Remote control light switch  
Commande murale pour allumage lumières

Alimentatore: Non installare nelle zone 0, 1 e 2  
Feeder: do not install in the areas 0, 1 and 2  
Source d'alimentation : NE PAS installer dans les zones 0, 1 et 2

Cavo Led 12Vac (5 mt.)  
Led cable 12 Vac (5 mt.)  
Câble LED (5 mt.)

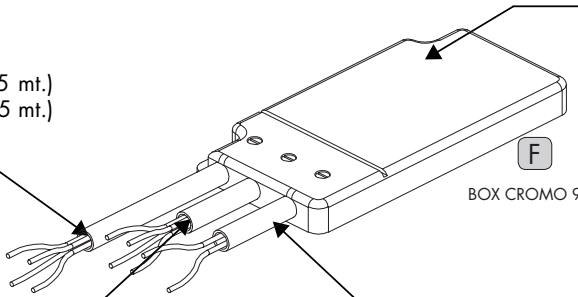

BOX CROMO 9

Cavo pulsante Led  
Led button cable  
Câble bouton LED  
12Vac (0,20 mt.)

Cavo Entrata 220Vac (0,20 mt.)  
Input Cable 220Vac (0,20 mt.)  
Câble entrée 220V (0,20 mt.)

PRESA ACQUA  
WATER FEED  
SORTIE EAU

Posizionare 1 Trasformatore all'esterno della zona 2 (nella zona 3)  
Place the current transformer outside area 2 (inside area 3)  
Installer 1 Transformateur à l'extérieur de la zone 2 (dans la zone 3)

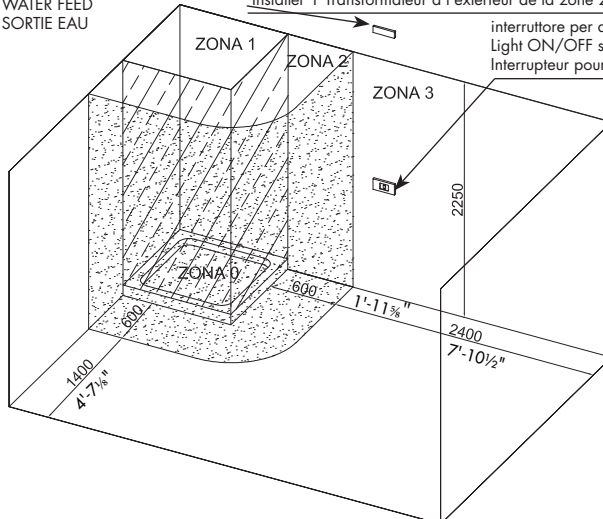

interruttore per alimentazione. Non in dotazione.  
Light ON/OFF switch. Not provided.  
Interrupteur pour alimentation. Non fourni.

Per tutte le versioni dei soffioni è necessaria l'installazione di un interruttore ON/OFF sull'alimentazione del trasformatore.  
All false ceiling shower heads require installation of control key for switch on/off lights on transformer power supply.  
Pour toutes les versions de plafonds de douche à encastrer à faux-plafond il faut installer un interrupteur marche/arrêt sur l'alimentation du transformateur qui vient fourni avec le produit.



All'interno delle zone ZONA 0 - ZONA 1 - ZONA 2 NON DEVE ESSERE MAI PRESENTE LA TENSIONE 220V  
ELECTRICAL CURRENT AT 220 V MUST NEVER BE PRESENT within areas 0 - 1 - and 2  
Dans les zones ZONE 0 - ZONE 1 - ZONE 2 Ne doit en aucun cas être présent la tension 220V

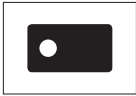

ITA

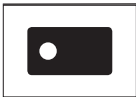
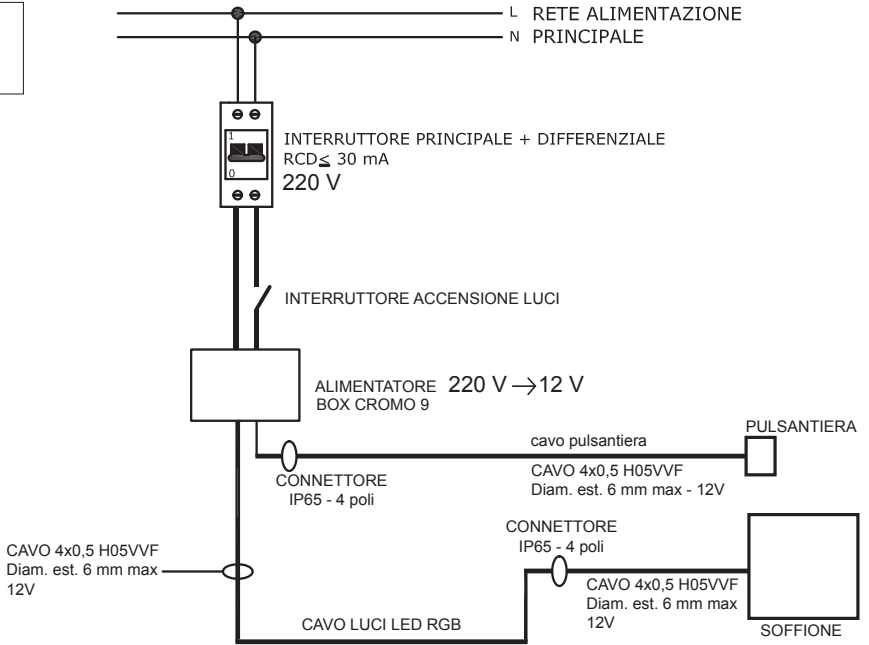

ENG  
FRA

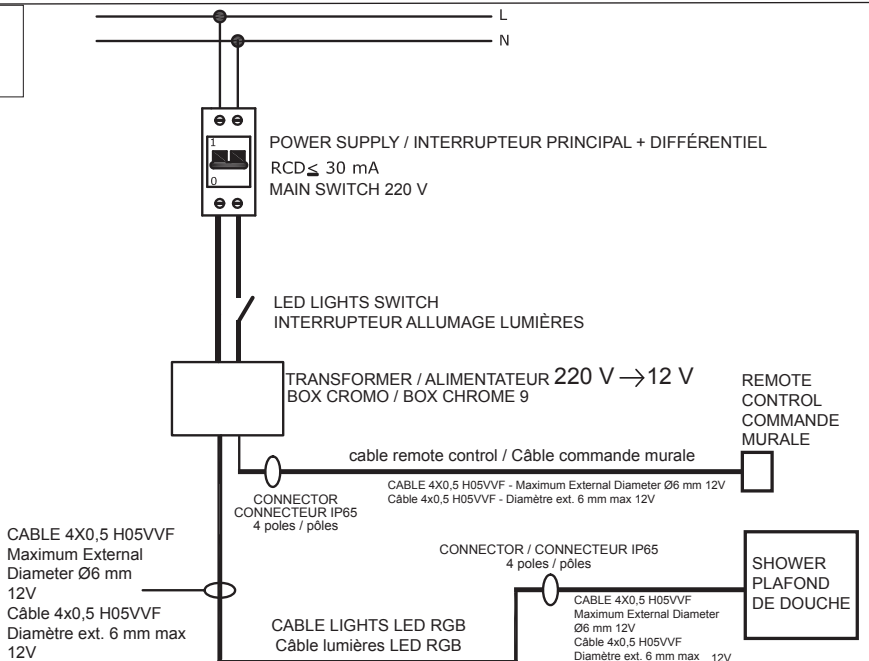

# Schema impianto idraulico-elettrico / Hydraulic-electric system layout Schéma d'installation hydraulique-électrique



Galaxy  
MCSQ-540  
Built-in  
Shower Head



x = 460 mm. (1'-6 $\frac{1}{2}$ " )  
Y = 460 mm. (1'-6 $\frac{1}{2}$ " )  
z = min 160 mm. / max 700 mm. (min 2'-3 $\frac{1}{2}$ " - max 6 $\frac{1}{4}$ " )

Per tutte le versioni dei soffioni è necessaria l'installazione di un interruttore ON/OFF sull'alimentazione del trasformatore.  
All false ceiling shower heads require installation of control key for switch on/off lights on transformer power supply.  
Pour toutes les versions de plafonds de douche à encastrer à faux-plafond il faut installer un interrupteur marche/arrêt sur l'alimentation du transformateur qui vient fourni avec le produit.

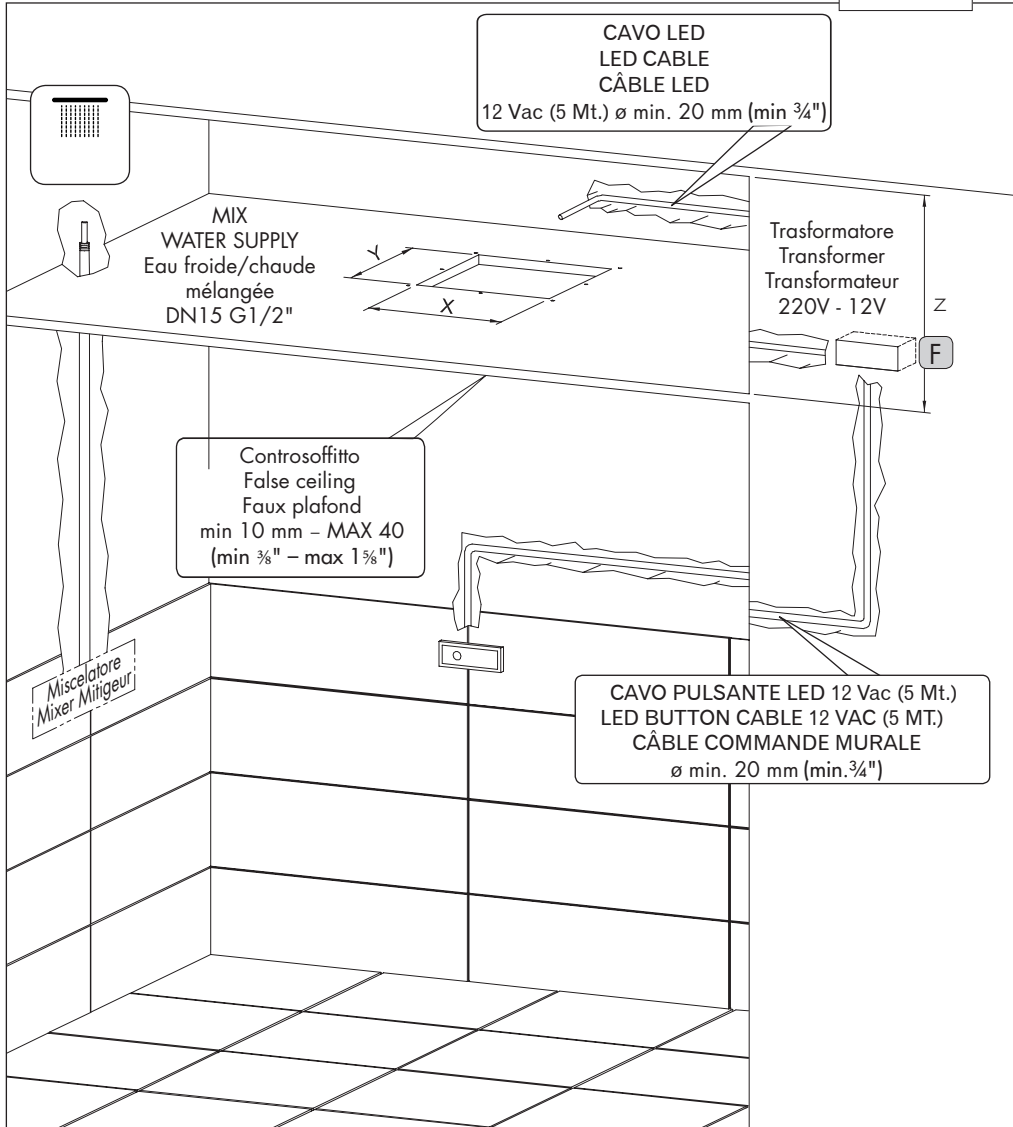
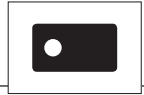

CAVO LED  
LED CABLE  
CÂBLE LED  
12 Vac (5 Mt.) ø min. 20 mm (min 3/4")

Trasformatore  
Transformer  
Transformateur  
220V - 12V  
Z  
F

Controsoffitto  
False ceiling  
Faux plafond  
min 10 mm - MAX 40  
(min 3/8" - max 1 3/8")

CAVO PULSANTE LED 12 Vac (5 Mt.)  
LED BUTTON CABLE 12 VAC (5 MT.)  
CÂBLE COMMANDE MURALE  
ø min. 20 mm (min. 3/4")

Miscelatore  
Mixer Mitigeur

a

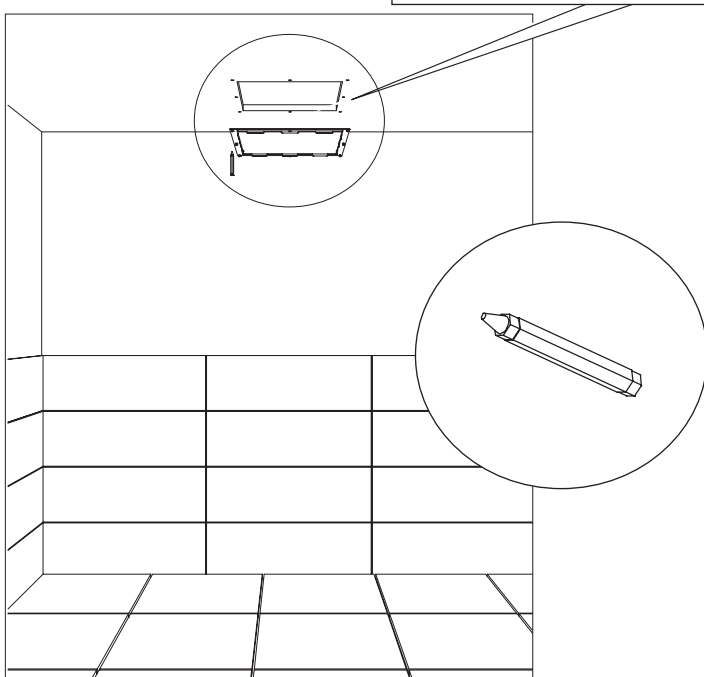
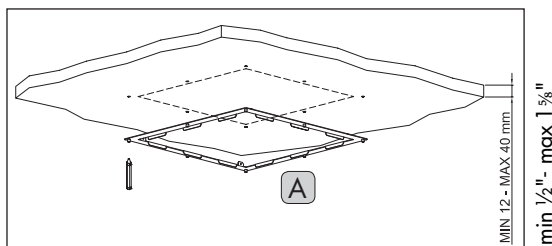

b

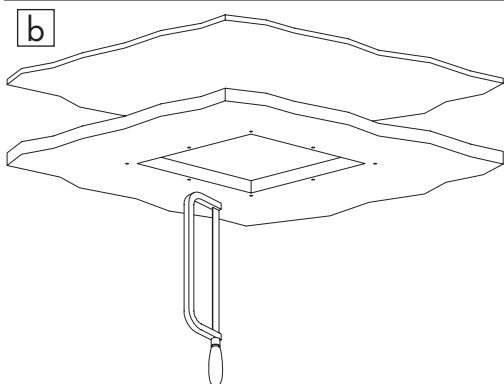

c

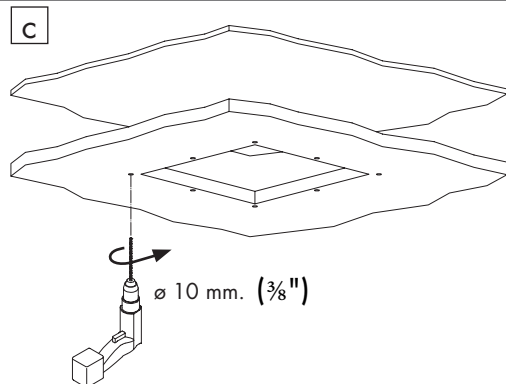

d

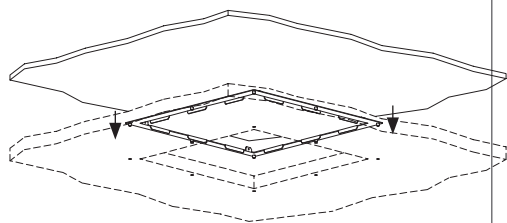

e

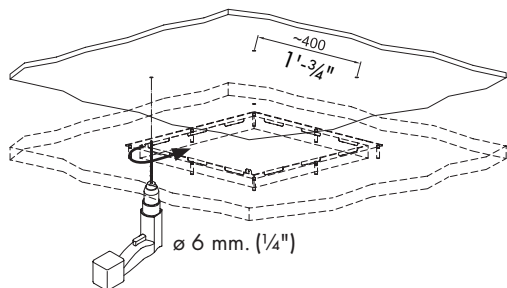

f

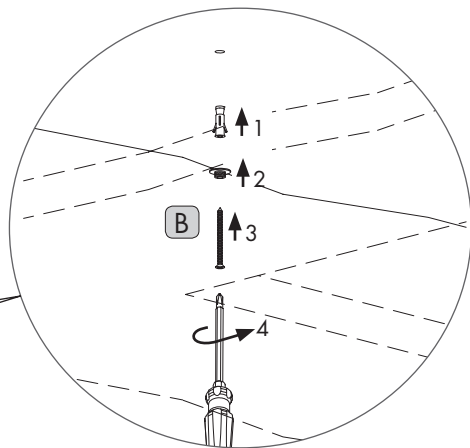
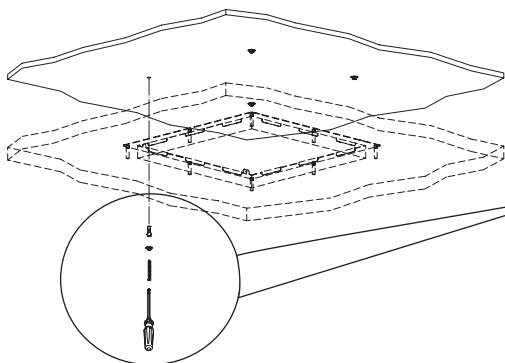

g

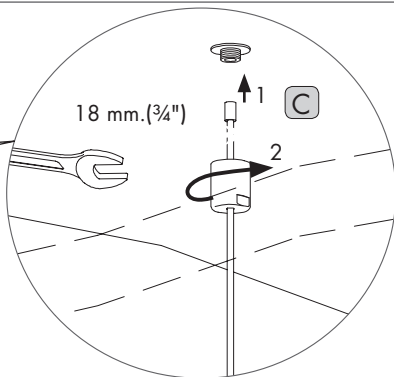
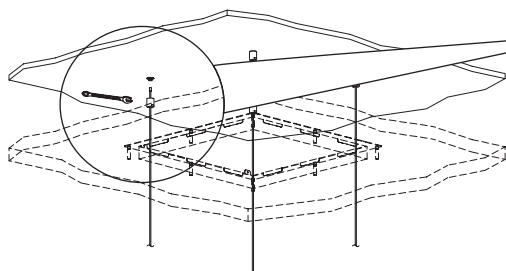

h

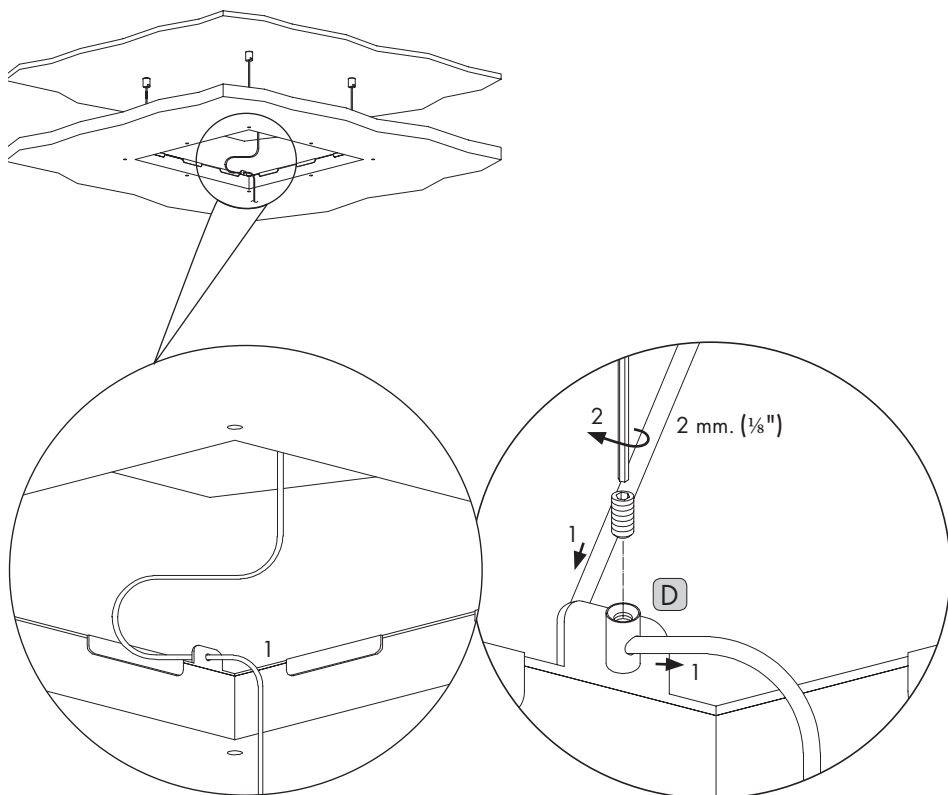



i

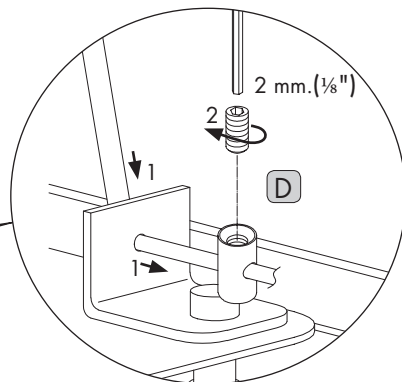
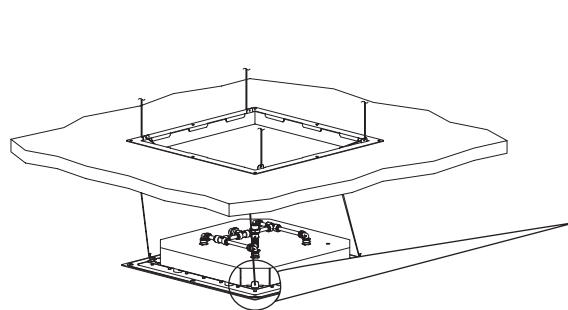
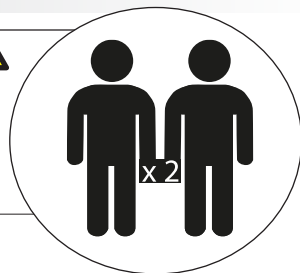
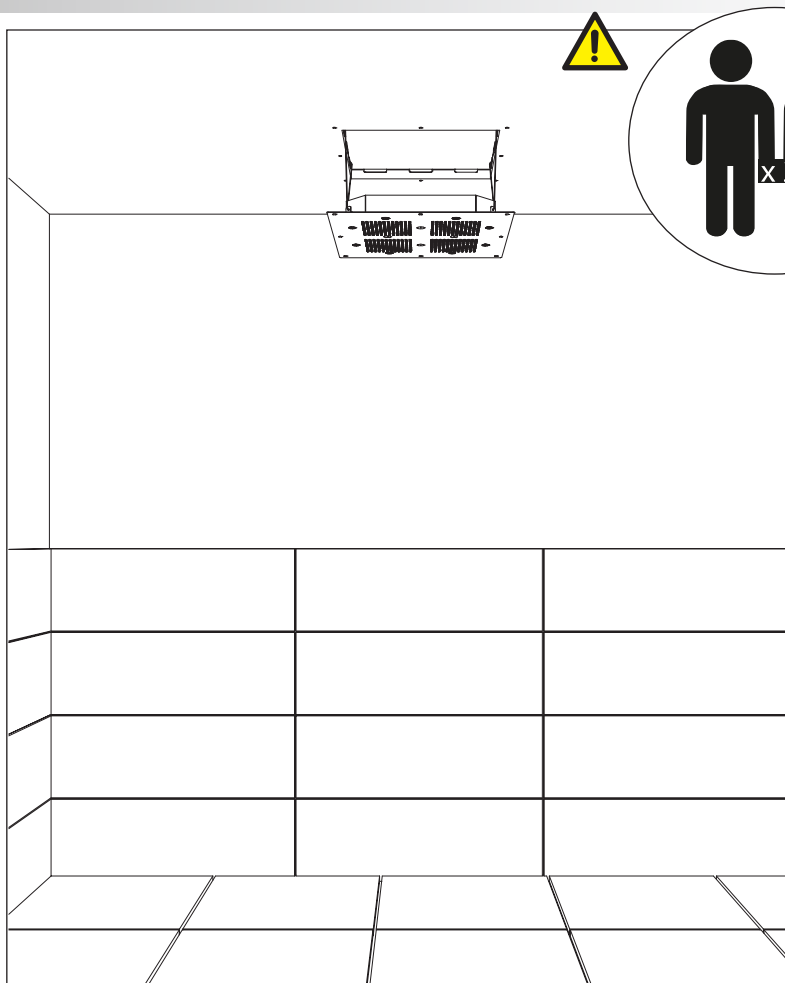

I

- Effettuare il collegamento idraulico/elettrico in base alla tipologia di soffione (Ved. pag. 4) the
- Make the connection to the hydraulic/electrical system according to type showerhead. (see pag. 4)
- Effectuer le branchement hydraulique/électrique en fonction du type de produit (voir page 4)

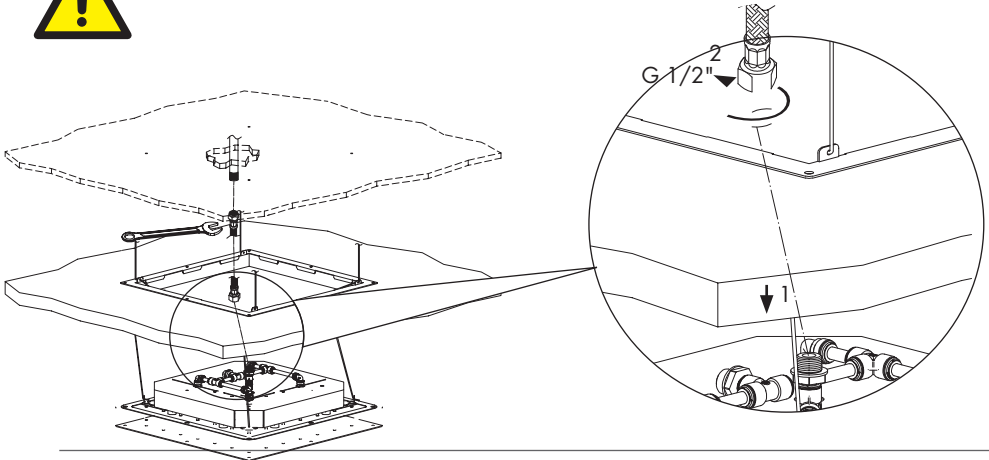

- Installare il tastierino, se previsto, seguendo le istruzioni da pag. 11, altrimenti proseguire dalla figura successiva "M"
- Install the keyboard, if applicable, following the instructions on page 11, otherwise continue with the figure "M"
- Installer la commande murale conformément aux instructions de page 11, autrement continuer jusqu'à la figure suivante "M"

m



- Fissare il soffione al controsoffitto e serrare le viti come indicato nella figura M, prestando particolarmente attenzione a non rovinare la finitura.
- Install the showerhead to the false ceiling and tighten the screw as shown in the figure M, be carefully, not scratch the surface.
- Fixer le produit à faux-plafond et serrer les vis comme indiqué dans la figure "M", en accordant une attention particulière à ne pas abimer la finition.

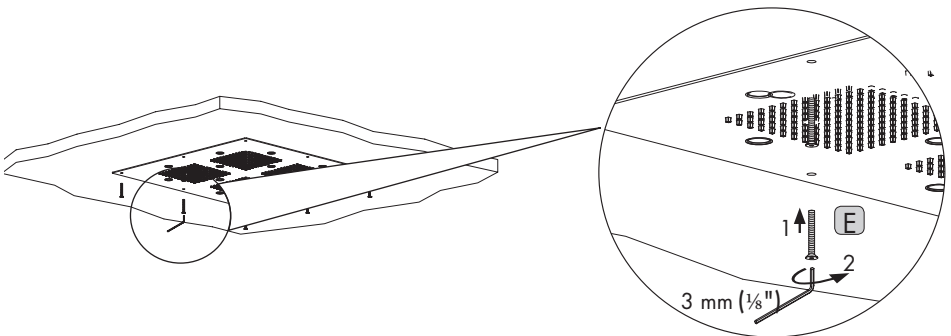

n

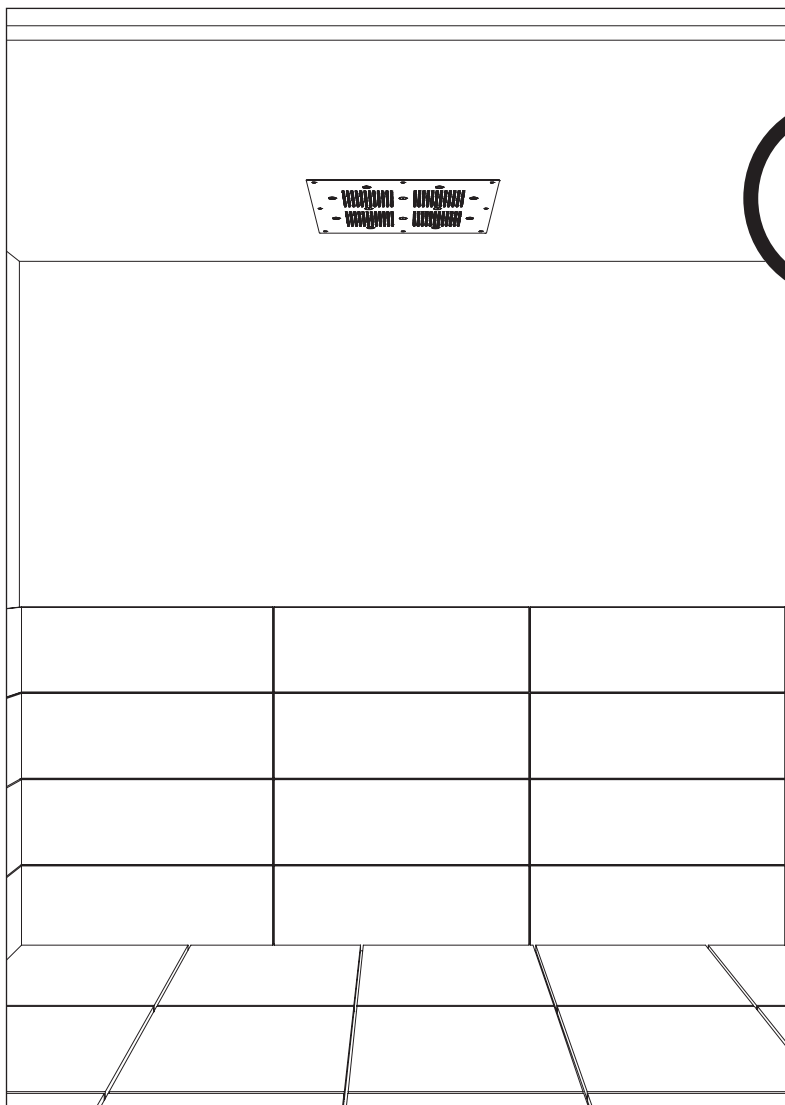

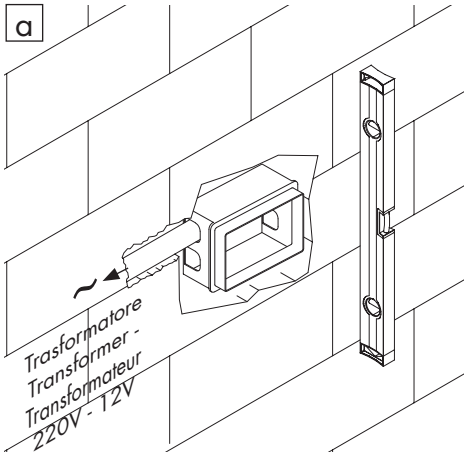

- Inserire nel muro la scatola di derivazione in dotazione e con l'ausilio di una livella posizionarla correttamente
- Insert the supplied junction box in the wall with the help of a level and position it properly
- Insérer dans le mur la boîte de dérivation fournie et utiliser un niveau à bulle d'air pour la positionner correctement.

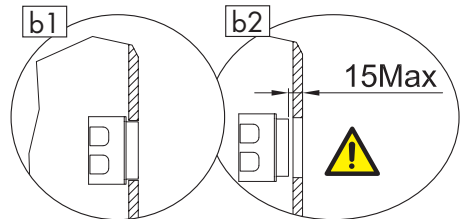
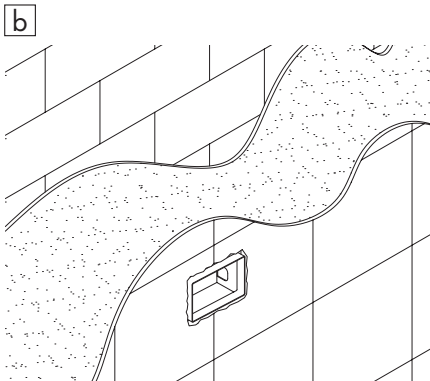

- Applicare il rivestimento e verificare che la scatola di derivazione sia a filo rivestimento (Fig. B1) o massimo 15 mm. (1/2") (Fig. B2)
- Apply the plate and make sure the junction box is aligned with the plate (Fig. B1) or at a maximum of 15 mm. (Fig. B2)
- Appliquer le revêtement et vérifier que la boîte de dérivation soit installée à fil du revêtement même (figure B1) ou maximum 15 mm. (figure B2).

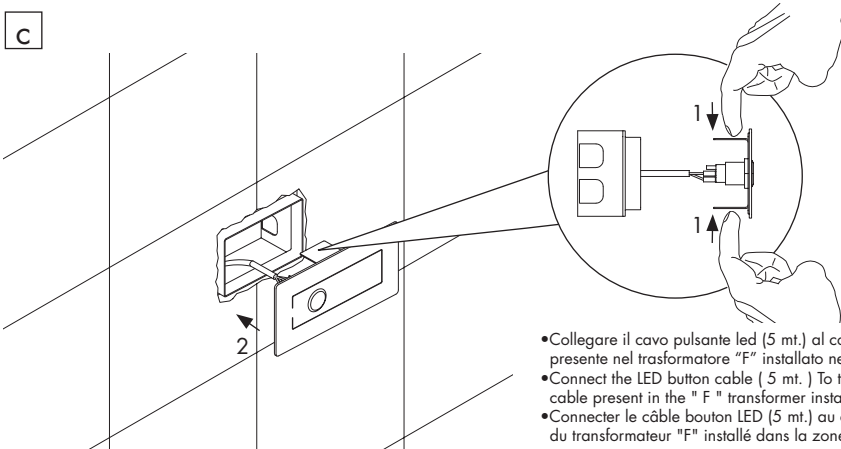

- Collegare il cavo pulsante led (5 mt.) al corrispondente cavo presente nel trasformatore "F" installato nella zona 3
- Connect the LED button cable (5 mt.) To the corresponding cable present in the "F" transformer installed in zone 3
- Connecter le câble bouton LED (5 mt.) au câble correspondant du transformateur "F" installé dans la zone 3

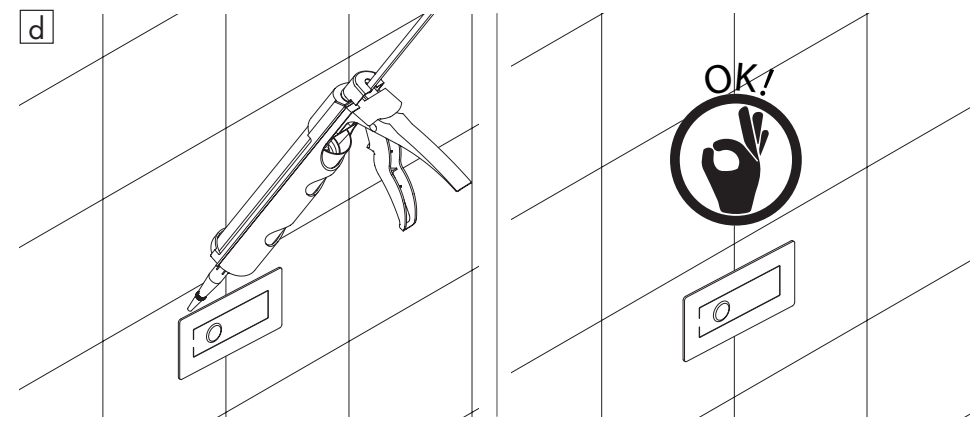

- Successivamente aver terminato l'installazione elettrica del tastierino all'interno del soffione, fissare quest'ultimo seguendo la sequenza "M" di pag. 19
- After finishing the installation of the electric keypad inside the shower head, fix the latter by following the sequence "M" on p. 19.
- Après avoir terminé l'installation électrique à l'intérieur du plafond de douche, fixer ce dernier respectant la séquence "M".

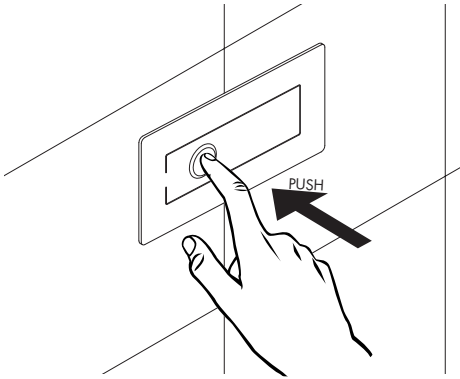

Push 	funzione	function	fonctions
1	on luce colore verde	on colour green	Allumage sur couleur vert

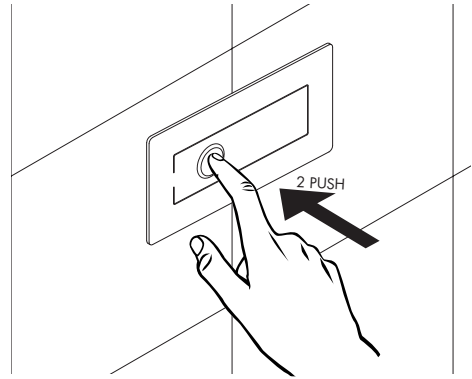

Push 	funzione	function	fonctions
1+1	colore azzurro	colour light blu	couleur azur
1+1	colore blu	colour blu	couleur bleu
1+1	colore viola	colour violet	couleur violet
1+1	colore rosso	colour red	couleur rouge
1+1	colore giallo	colour yellow	couleur jaune
1+1	colore arancione	colour orange	couleur orange

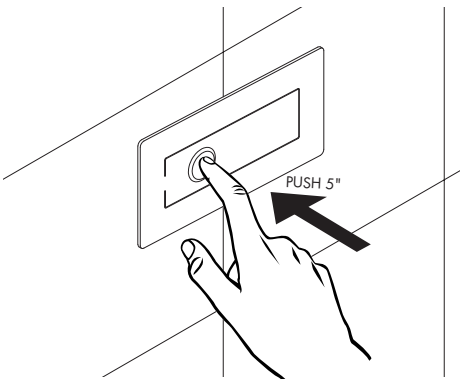

Push 	funzione	function	fonctions
1 - 5"	loop automatico colori	automatic loop colors	Cycle automatique couleurs

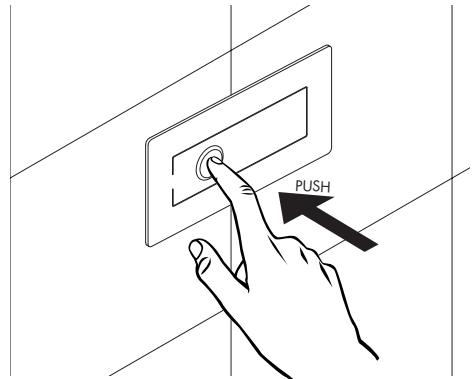

Push 	funzione	function	fonctions
1	spengimento luci	OFF light	Éteindre lumières LED RGB

a

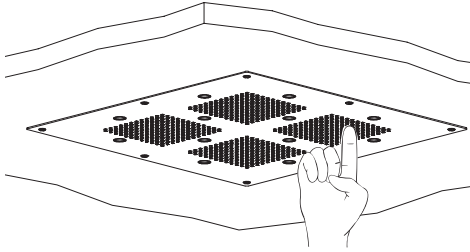

- Periodicamente pulire gli ugelli anticalcare come mostrato in figura "a"
- Periodically clean the nozzles to remove any lime scale as shown in Illustration "a"
- Nettoyer périodiquement les picots anticalcaire comme visualisé dans la figure "a".

Per preservare la qualità del prodotto AQUAelite si raccomanda di pulire le superfici in finitura esclusivamente con acqua e sapone neutro asciugandole con un panno morbido.

Non utilizzare detergenti o detersivi abrasivi o contenenti alcool, acidi, candeggina, cloro, solventi chimici, spugne abrasive, paglie metalliche, etc.

L'acqua contiene calcare in quantità variabili, il quale può depositarsi sulla superficie del prodotto formando macchie e depositi. E' possibile evitare la formazione di macchie di calcare pulendo ed asciugando il prodotto dopo ogni utilizzo.

Per evitare la formazione di calcare sugli ugelli strofinarli periodicamente con un panno umido.

In order to maintain the quality of AQUAelite products, surfaces must be cleaned exclusively using soapy water and dried with a soft cloth. Never use detergents, powders or creams containing alcohol, acid, bleach, solvents, chemical agents, metal or abrasive sponges, etc.

Water contains limestone in variable quantity, which can remain on the surfaces leaving spots and forming deposits.

In order to avoid limestone deposits clean and dry the product immediately after use. It is possible to prevent limestone deposits on nozzles by regularly rubbing with a damp cloth.

Pour préserver la qualité du produit AQUAelite est fortement recommandé de nettoyer les surfaces uniquement avec de l'eau et du savon neutre, ensuite sécher avec un chiffon délicat.

N'utiliser PAS des détergents ou produits abrasifs ou avec un contenu d'alcool, acides, candéguine, chlôre, solvants chimiques, éponges abrasives, paglie métalliques, etc.

L'eau contient du calcare en quantité variable, il peut se déposer sur la surface du produit et former des taches ou sédiments.

Il est possible d'éviter la formation de taches de calcare en nettoyant et séchant le produit après chaque utilisation.

Pour éviter la formation de calcare dans/sur les picots, il est fortement conseillé de les nettoyer périodiquement avec un chiffon délicat et humide.

## CARATTERISTICHE TECNICHE

Tensione di alimentazione: 12Vcc +/- 3%  
Assorbimento massimo: 1.3 A – 8.4 A  
Servizio di funzionamento: Continuo  
Temperatura ambiente di funzionamento: da 0 a +40°C  
Umidità relativa senza condensa: 5% a 90%  
Grado di protezione: IP55  
Connessioni d'ingresso e d'uscita: Morsetto a carrello  
Norma di sicurezza: Non richiesta  
Norma ENIC: EN55022/B



### Prodotto LASER di Classe 2

Le radiazioni luminose di questa classe sono considerate a basso rischio, ma potenzialmente pericolose. Normalmente non producono danni permanenti se viste per pochi istanti da un occhio non protetto.

## AVVERTENZE

Prima di collegare l'unità per la prima volta, leggere attentamente le sezioni seguenti. I voltaggi CA delle reti elettriche variano a seconda del paese.  
Assicurarsi che il voltaggio presente nella vostra zona sia conforme con il voltaggio richiesto.



### ALIMENTATORE

Tensione di alimentazione:  
ingresso 190 -230 VAC 50/60Hz +/- 20%  
uscita - 12Vcc +/- 3%  
Potenza: 48 Watt

Si consiglia vivamente di utilizzare l'alimentatore fornito da Anpa; In caso di utilizzo di alimentatore diverso assicurarsi che le caratteristiche richieste siano compatibili con l'apparecchio. L'utilizzo di alimentatori con caratteristiche diverse o incompatibili possono danneggiare irreparabilmente il prodotto e far decadere la garanzia.

## TECHNICAL FEATURES

Voltage supply: 12 Vcc +/- 3%  
Maximum consumption: 1.3 A – 8.4 A  
Functioning: Continuous  
Ambient operating temperature: 0- +40 °  
Relative non-condensing humidity: 5% -90%  
Protection degree: IP55  
Input and output connection: Rising clamp terminal block  
Safety standard: Not required  
Enic standard: EN55022/b



### Class 2 LASER product

Class 2 light radiations are considered as posing a low risk, but potentially dangerous.

## WARNING

Before connecting the unit for the first time, please read carefully the following sections.  
AC voltages varies according to each country.  
Ensure that the voltage of your local power supply corresponds to the required voltage.



### FEEDER

Voltage supply:  
Input 190 -230 VAC 50/60Hz +/- 20%  
output - 12Vcc +/- 3%  
Power: 48 Watt

It is strongly recommended to use the feeder provided by anpa. If a different feeder is to be used, please ensure that is compatible with the device.  
The use of feeders with different characteristics or incompatible may damage the product and invalidate the warranty.

DICHIARAZIONE DI CONFORMITÀ

Noi,



**ANPA srl**

Viale dello Sport 16/18 - 21026 Gavirate (VA) Italy

Dichiariamo che il prodotto descritto in questo manuale è conforme alla Direttiva 2006/95/CE relativa al "Materiale elettrico destinato ad essere adoperato entro taluni limiti di tensione" e alla Direttiva 2004/108/CE relativa alla "Compatibilità" Elettromagnetica"

DECLARATION OF CONFORMITY

We,



**ANPA srl**

Viale dello Sport 16/18 - 21026 Gavirate (VA) Italy  
declare that the product featured in these instructions conforms to Directive 2006/95/CE relating to "Electrical equipment designed for use within certain voltage limits" and to Directive 2004/108/CE relating to "Electromagnetic compatibility".



**CARACTÉRISTIQUES TECHNIQUES**

Tension d'alimentation : 12Vcc +/- 3%  
 Adsorption maximale : 1.3 A - 8.4 A  
 Service de fonctionnement : continu  
 Température ambiante de fonctionnement : de 0 à +40°  
 Humidité relative sans condensation : de 5% à 90%  
 Degrée de protection : IP55  
 Connexions d'entrée et de sortie : bornes à bogies  
 Normes de sécurité : non demandée  
 Norme ENIC : EN55022/B

**Produit LASER Classe II**

Les radiations lumineuses de cette Classe sont considérées à bas risque, mais dangereuses potentiellement.  
 Normalement ne produisent pas des dégâts permanents si vu pour quelque instant d'un œil sans protection.

**AVERTISSEMENTS**

Avant de brancher l'unité la première fois, veuillez lire attentivement les sections suivantes.  
 Les voltages des réseaux électriques varient à second du pays.  
 S'assurer que le voltage dans votre zone soit conforme avec le voltage prévu et déclaré par l'usine.

**ALIMENTATEUR**

Tension d'alimentation :  
 entrée 190 - 230 VAC 50/60Hz +/- 20%  
 sortie - 12Vcc +/- 3%  
 Puissance : 48W

Il est fortement recommandé d'utiliser l'alimentateur fourni avec le produit.  
 En cas d'utilise d'un alimentateur différent, s'assurer que les caractéristiques demandées soient compatibles avec l'appareil.  
 L'utilise d'alimentateurs avec caractéristiques différentes ou incompatibles puissent endommager le produit irrémédiablement et faire invalider la garantie.

DÉCLARATION DE CONFORMITÉ



Nous,

**ANPA srl**

Viale dello Sport 16/18 - 21026 Gavirate (VA) Italy

Déclarons que le produit décrit dans cette guide est conforme à la Directive 2006/95/CE relative au "Matériel électrique destiné à être employé dans certains limites de tension" et à la Directive 2004/108/CE relative à la "Compatibilité Électromagnétique".

#### Dati tecnici generali per l'impianto idraulico

Pressione minima di esercizio: 1,5 bar

Pressione di esercizio: campo di impiego ottimale consigliato 2,5 - 4 bar

Pressione massima di esercizio: 5 bar

(Per pressioni idrauliche superiori si consiglia l'utilizzo di un riduttore di pressione)

Temperatura massima di esercizio: 65 °C

I soffioni a parete sono dotati di limitatore di portata 12 lt/min. (ove possibile).

#### Funzionamento minimo dei soffioni ad incasso:

Getto a pioggia: 16 lt/min. - 1,5 bar (4,23 gal / min)

Cascata singola: 10 lt/min. - 2 bar (2,64 gal / min)

Doppia cascata: 14 lt/min. - 2 bar (3,7 gal / min)

Funzionamento ottimale dei soffioni ad incasso:

Getto a pioggia: 18 lt/min. - 2,5 bar (4,76 gal/min)

Cascata singola: 14 lt/min. - 2,5 bar (3,7 gal/min)

Doppia cascata: 17 lt/min. - 2,5 bar (4,5 gal/min)



#### PROTEZIONE AMBIENTALE

I dispositivi elettrici ed elettronici non devono essere considerati rifiuti domestici. I consumatori sono obbligati dalla legge a restituire i dispositivi elettrici ed elettronici alla fine della loro vita utile ai punti di raccolta collettivi preposti per questo scopo o nei punti vendita.

#### Technical information for the hydraulic system

Minimum operating pressure: 1,5 bar

Operating Pressure: Optimal recommended use 2.5- 4 bar

Maximum operating pressure: 5 bar

(for higher hydraulic pressure it is recommended a pressure reducer)

Maximum operating temperature: 65 °C

Wall mount shower heads are equipped with a 12 l/m flow rate reducer (where possible).

#### Minimum supply required for false ceiling shower heads:

Rain function: 16 lt/min. - 1,5 bar (4,23 gal / min)

Cascade function: 10 lt/min. - 2 bar (2,64 gal / min)

Double cascade function: 14 lt/min. - 2 bar (3,7 gal / min)

Optimal supply for false ceiling shower heads:

Rain function: 18 lt/min. - 2,5 bar (4,76 gal/min)

Cascade function: 14 l/m - 2,5 bar (3,7 gal/min)

Double cascade function: 17 l/m - 2,5 bar (4,5 gal/min)



#### ENVIRONMENTAL PROTECTION

Electrical and electronic equipment is not to be treated as domestic refuse.

Consumers are obliged by law to dispose of no-longer useful electrical and electronic equipment at the appropriate collection or sales points.

#### Données techniques générales pour installation hydraulique

Pression minimale d'exercice: 1,5 bar

Pression d'exercice optimale: 2,5 - 4 bar

Pression maximale d'exercice: 5 bar

(pour pressions hydrauliques supérieures, l'utilisation d'un réducteur de pression est fortement recommandée)

Température maximale d'exercice : 65 °C

Les pommes de douche à mur sont équipées d'un limiteur de débit d'eau à 12 lt/min. (ou possible).

#### Fonctionnement minimal des plafonds de douche à encastrer à faux-plafond:

Jet pluie: 16 lt/min. - 1,5 bar (4,23 gal / min)

Jet cascade single: 10 lt/min. - 2 bar (2,64 gal / min)

Jet cascade double: 14 lt/min. - 2 bar (3,7 gal / min)

#### Fonctionnement optimale des plafonds de douche à encastrer à faux-plafond:

Jet pluie: 18 lt/min. - 2,5 bar (4,76 gal/min)

Jet cascade single: 14 lt/min. - 2,5 bar (3,7 gal / min)

Jet cascade double: 17 lt/min. - 2,5 bar (4,5 gal/min)



#### ENVIRONNEMENT

Les dispositifs électriques et électroniques NE doivent PAS être considérés comme des déchets domestiques.

Les consommateurs sont obligés par la loi à retourner les dispositifs électriques et électroniques, à la fin de leur vie utile, aux points de collecte collectifs faits pour ça ou aux points de vente.